

ZIMM[®]

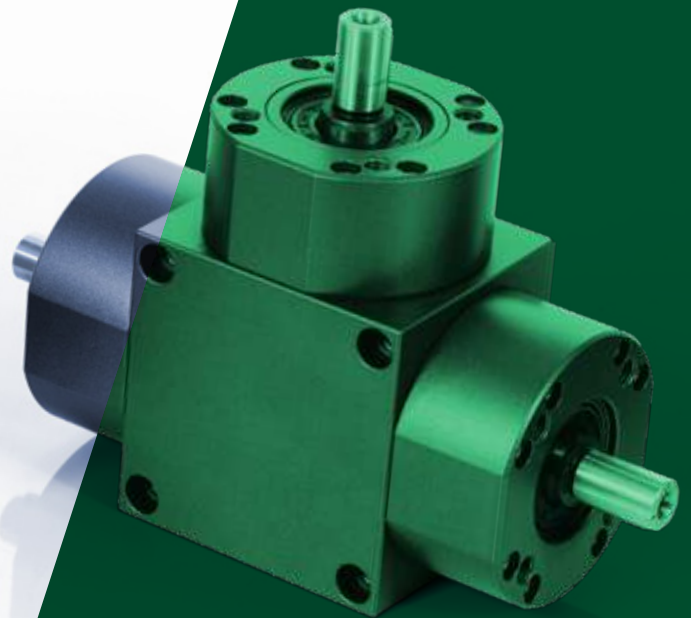
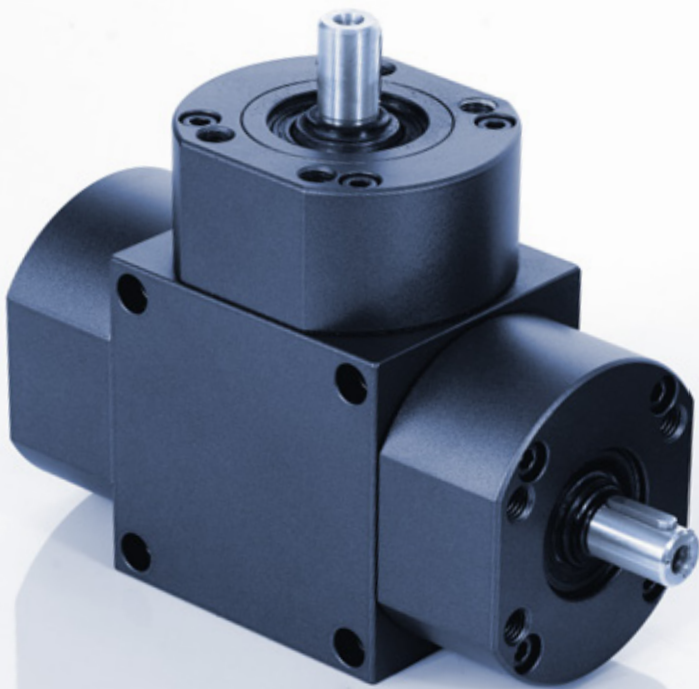

the new

Bevel Gearboxes

KSZ-H model range

Quality and experience
for over 40 years!

New Bevel Gearboxes

KSZ-H Model Range

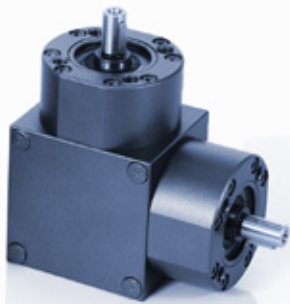

All from one source

Now available in 7 sizes in the L and T variants

Combine the bevel gearbox, screw jack system, couplings, connecting shafts, motors and motor flanges to suit the requirements of each of your applications.

Now up to 60% more torque

Torque up to 60% higher than the previous KSZ range for the same physical size.

Now in 3 drive ratios

» 1:1 » 2:1 » 3:1

Now corrosion-resistant coated as standard

The two-component paint finish and smooth surface ensure a long working life and resistance to contamination of the gearbox.

Connecting shafts

ZIMM VWZ shafts of 500 mm length and more are checked for concentricity as standard.

Couplings

- » Great product range
- » Convenient mounting option
- » High concentricity, high clamping forces
- » Low moment of inertia
- » Stepless adjustment facility due to the clamp hub rather than a fitted drive key.

Content



Motor flange MF

MF for direct mounting of a three-phase AC motor.



Through-bore

Now with a through-bore for easy installation

Topic	pages
Bevel gearbox	4 - 5
Flange combinations	6 - 7
Couplings	8 - 9
Connecting shafts	10 - 11
Pedestal bearing STL	12 - 13
ZIMM Product Configurator	14 - 15



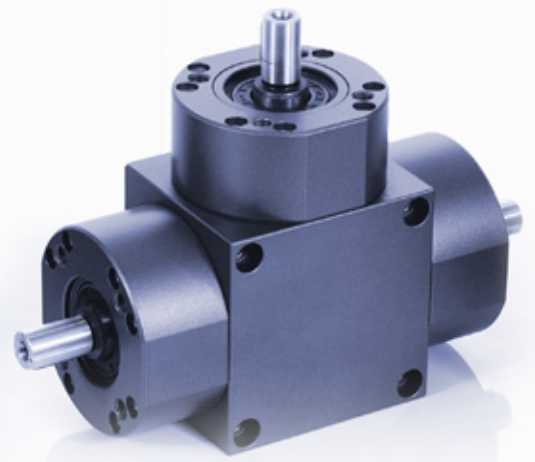

Bevel Gearboxes

KSZ-H Model Range

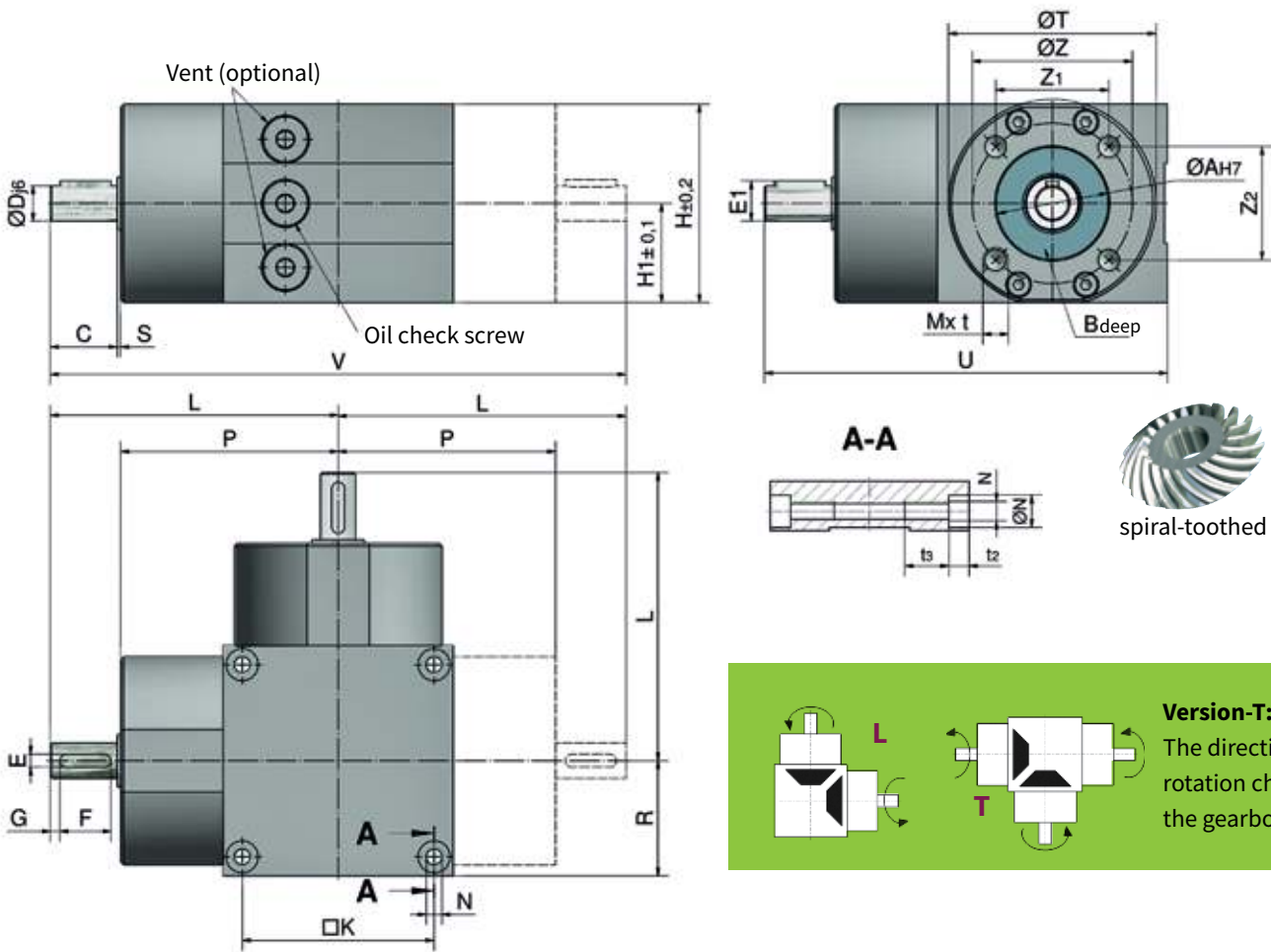

Dimensions

Bevel Gearboxes KSZ-H 5 to 150kN

Part no.	ØAH7	B	C	Dj6	Eh9	E1	F	G	H	H1	ØK	L	M	t	N	ØN	t2	t3	P	R	S	ØT	U	V	ØZ	Z1	Z2
KSZ-H-5-L/T	35	3	21	11	4	12.5	16	3	62	31	60	90	M8	12	M6	10	6.4	20	68	36	1	65 ¹	126	180	50	35.4	35.4
KSZ-H-10-L/T	40	3	26	14	5	16	20	3	74	37	70	105	M8	12	M8	11	8.2	25	77.5	42.5	1.5	77 ²	147.5	210	59.4	42	42
KSZ-H-25-L/T	42	3	27	16	5	18	22	3	82	41	78	117	M10	15	M8	11	8.2	25	88.5	47.5	1.5	91 ³	164.5	234	71.7	62	36
KSZ-H-35-L/T	52	4	34	19	6	21.5	28	3	100	50	98	150	M10	20	M10	15	10.2	30	114	60	2	102 ⁴	210	300	86	70	50
KSZ-H-50-L/T	52	4	39	20	6	22.5	32	3	116	58	110	165	M10	20	M12	20	12.6	30	124	67.5	2	126 ⁵	232.5	330	86	50	70
KSZ-H-100-L/T	62	4	45	32	10	35	40	3	160	80	154	235	M12	22	M12	20	12.6	35	188	94	2	170 ⁶	329	470	106.5	46	96
KSZ-H-150-L/T	62	5	53	38	10	41	50	1.5	185	92.5	180	275	M12	22	M16	26	15.1	40	220	110	2	188 ⁷	385	550	106.5	46	96

Supplementary drive ratios (1:1, 2:1, 3:1) KSZ-H provides up to 60% more torque

Material specifications:

- Housing material: EN-GJL-200 (GGL 20)
- Low-backlash version
- Quiet running
- High torque transmission in a small size
- Pre-loaded taper roller bearings
- Sealing by means of shaft seals and O-rings
- Max. 40% duty factor at 1500 rpm
- Permanent lubrication with oil; oil change required only on heavy duty applications
- Compatible with screw jack modular components
- All installation dimensions symmetrical

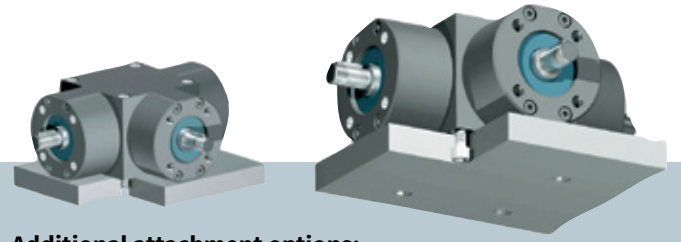

Additional attachment options:

The new KSZ-H series offers an additional attachment option. Besides the standard internal threads for screw connection from below, the special design of the bores now also permits screw connection from above.

The newly added bevel gearbox series are allowing supplementary drive ratios (1:1, 2:1, 3:1) and offering up to 60% more torque than its predecessor. The new KSZ-H gearbox is highly versatile and delivers more power from the same size. A total of seven sizes in types L and T providing you with a wide range of combination options.

Technical data

Bevel Gearboxes KSZ-H 5 to 150kN

Size	i	Permissible torque (drive shaft) Nm at various speeds rpm					Moment of inertia kg cm ²		F _{Radial} N	Weight kg	
		100	500	1000	1500	3000	L	T		L	T
KSZ-H-5-L/T	1:1	21	19.8	19.8	19.8	17	0.614	0.748	140	3.1	3.7
	2:1	14	13.7	13.7	13.5	13.2	0.614	0.748	140	3.1	3.7
	3:1	10	10	10.1	10.1	10	0.614	0.748	140	3.1	3.7
KSZ-H-10-L/T	1:1	44.4	41.9	40.2	35.2	28.7	1.855	2.422	200	4.8	6
	2:1	27.5	27.2	27	26.7	26	1.855	2.422	200	4.8	6
	3:1	20.1	20	20	19.9	19.7	1.855	2.422	200	4.8	6
KSZ-H-25-L/T	1:1	72	71	60	52.5	42	3.38	4.215	300	7.2	9.1
	2:1	41	40	40	40	38	3.38	4.215	300	7.2	9.1
	3:1	34	34	33.5	33.5	33	3.38	4.215	300	7.2	9.1
KSZ-H-35-L/T	1:1	162	160	155	135	110	11.055	14.055	550	10.6	14.1
	2:1	78	77	76	74	70	11.055	14.055	550	10.6	14.1
	3:1	51	51	50.5	50	49	11.055	14.055	550	10.6	14.1
KSZ-H-50-L/T	1:1	162	160	158	155	125	11.586	16.269	1100	17	21.4
	2:1	145	144	143	141	115	11.586	16.269	1100	17	21.4
	3:1	100	100	99	98	93	11.586	16.269	1100	17	21.4
KSZ-H-100-L/T	1:1	507	466	455.5	450.5	370	107.8	126.074	1600	54	70.6
	2:1	410	410	400	400	320	107.8	126.074	1600	54	70.6
	3:1	315	315	313	311	320	107.8	126.074	1600	54	70.6
KSZ-H-150-L/T	1:1	781	719.4	703.6	680	540	206.407	236.908	2500	82.1	103
	2:1	675	670	664	657	555	206.407	236.908	2500	82.1	103
	3:1	500	497	494	490	435	206.407	236.908	2500	82.1	103



Ordering example:

Bevel Gearboxes _____ KSZ-H-50-T-1:1
 Size _____
 L or T shaft configuration _____
 Drive ratio _____



Motor flange combinations

for Bevel Gearboxes KSZ-H

Bevel Gearboxes KSZ-H-5 to KSZ-H-10 Motor Flange Combinations

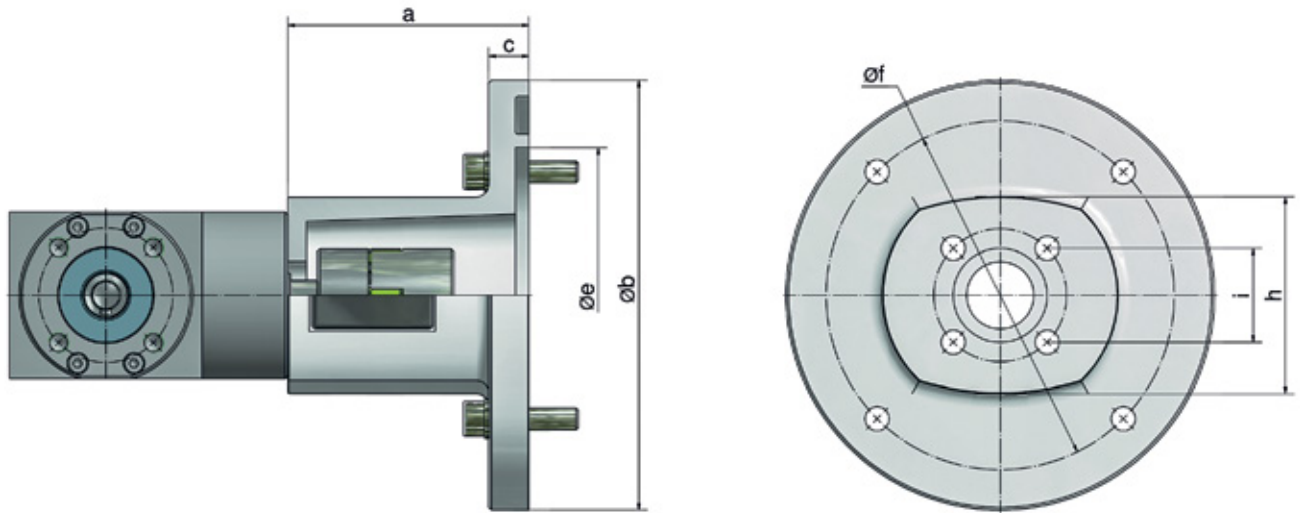

Dimensions

Bevel Gearboxes KSZ-H 5 to 10kN

Size KSZ-H	Motor flange part no.	Motor type	Coupling part no. Bore \varnothing		4 of screws gearbox side 8.8 DIN 7991	4 of socket head cap screws 8.8 DIN 912 (for motor)	a	b	c	e	f	h	i	kg	Transmittable torque Nm ³⁾	
			Size	Gearbox Motor											max.	max.
KSZ-H-5	Z-10-MF-120-66	63 B14B	KUZ-19	- 11 / 11	M8x16	M6x20 ¹⁾	66	120	10	80	100	73	35.4	0.42	6.1	6.1
KSZ-H-5	Z-10-MF-160-75	71 B14C	KUZ-19	- 11 / 14	M8x16	M8x35 ²⁾	75	160	15	110	130	73	35.4	0.81	5.5	5.5
KSZ-H-5	Z-10-MF-160-90	80 B14B	KUZ-24	- 11 / 19	M8x16	M8x30 ¹⁾	90	160	15	110	130	73	35.4	0.88	13.4	13.4
KSZ-H-10	Z-25-MF-160-105	71 B5	KUZ-28	- 14 / 14	M8x20	M8x35 ²⁾	105	160	15	110	130	81	42	1.11	22.7	22.7
KSZ-H-10	Z-25-MF-160-105	80 B14B	KUZ-28	- 14 / 19	M8x20	M8x30 ¹⁾	105	160	15	110	130	81	42	1.11	27.7	27.7
KSZ-H-10	Z-25-MF-160-105	90 B14B	KUZ-24	- 14 / 24	M8x20	M8x30 ¹⁾	105	160	15	110	130	81	42	1.11	17	27.7
KSZ-H-10	Z-25-MF-160-122	100 B14C	KUZ-28	- 14 / 28	M8x20	M8x30 ¹⁾	122	160	15	110	130	81	42	1.25	27.7	27.7

1) incl. spring washers 2) incl. nuts 3) only valid for these combinations. CAUTION: Permissible torque for each KSZ-H must be observed.



Please note, KSZ-H size 5 up to 35 requires a one motor flange size bigger (e.g. KSZ-H-5 requires Z-10-MF).

Bevel Gearbox Motor Flange Combo MF (1 pcs.) - KSZ-H 25 to 150 kN

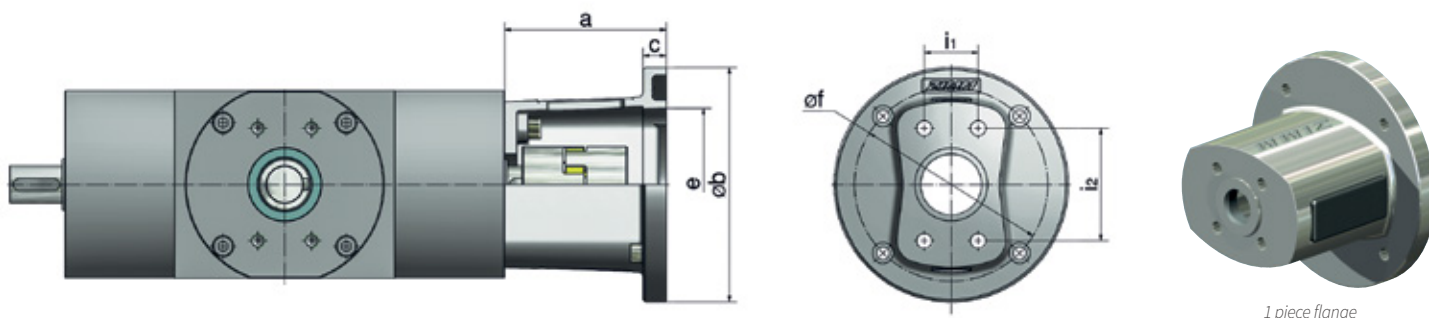

1 piece flange

Bevel Gearbox Motor Flange Base MF-B and Motor flange Plate MF-P (2 pcs.) - KSZ-H 25 to 150 kN

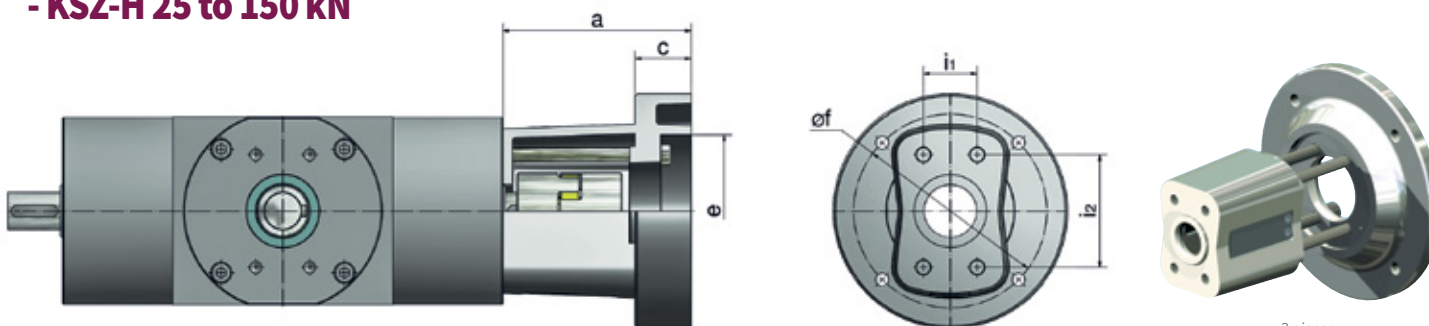

2 pieces,
1x Base, 1x Plate

Please note, KSZ-H size 5 up to 35 requires a one motor flange size bigger (e.g. KSZ-H-5 requires Z-10-MF).

Dimensions

Bevel Gearboxes KSZ-H 25 to 150kN

Size KSZ-H	Motor flange part no.	Motor type	Coupling part no. Bore Ø		4 screws gearbox side DIN 912	4 of socket head cap screws 8.8 DIN 912 (for motor)		a	b	c	e	f	i1	i2	kg	Transmittable torque Nm ³⁾	
			Size	Gearbox		Motor	max.										
KSZ-H-25	Z-35-MF-160-111	80 B14B	KUZ-24	-16 / 19	M10x30	M8x251)	111	160	15	110	130	36	62	2.6	17	34	
KSZ-H-25	Z-35-MF-160-111	90 B14B	KUZ-24	-16 / 24	M10x30	M8x251)	111	160	15	110	130	36	62	2.6	17	25.9	
KSZ-H-25	Z-35-MF-B+Z-35-MF-P-200	100 B14B	KUZ-28	-16 / 28	M10x120	M10x301)	123	200	12	130	165	36	62	3.6	25.9	25.9	
KSZ-H-25	Z-35-MF-B+Z-35-MF-P-200	112 B14B	KUZ-28	-16 / 28	M10x120	M10x301)	123	200	12	130	165	36	62	3.6	25.9	25.9	
KSZ-H-35	Z-50-MF-200-116	90 B5	KUZ-28	-19 / 24	M10x30	M10x452)	116	200	20	130	165	50	70	4.1	60	72.7	
KSZ-H-35	Z-50-MF-200-126	100 B14B	KUZ-28	-19 / 28	M10x30	M10x351)	126	200	20	130	165	50	70	4.3	60	72.7	
KSZ-H-35	Z-50-MF-200-126	112 B14B	KUZ-28	-19 / 28	M10x30	M10x351)	126	200	20	130	165	50	70	4.3	60	72.7	
KSZ-H-50	Z-50-MF-200-116	90 B5	KUZ-28	-20 / 24	M10x30	M10x452)	116	200	20	130	165	50	70	4.1	60	120	
KSZ-H-50	Z-50-MF-200-116	100 B14B	KUZ-28	-20 / 28	M10x30	M10x351)	126	200	20	130	165	50	70	4.3	60	120	
KSZ-H-50	Z-50-MF-200-126	112 B14B	KUZ-28	-20 / 28	M10x30	M10x351)	126	200	20	130	165	50	70	4.3	60	120	
KSZ-H-100	Z-100/150-MF-200-138	100 B14B	KUZ-38	-32 / 28	M12x40	M10x351)	138	200	20	130	165	46	96	5.2	160	164	
KSZ-H-100	Z-100/150-MF-200-138	112 B14B	KUZ-38	-32 / 28	M12x40	M10x351)	138	200	20	130	165	46	96	5.2	160	164	
KSZ-H-100	Z-100/150-MF-B+P-200	132 B14C	KUZ-38	-32 / 38	M12x150	M10x651)	161	200	48	130	165	46	96	8.7	160	164	
KSZ-H-150	Z-100/150-MF-200-138	100 B14B	KUZ-38	-38 / 28	M12x40	M10x351)	138	200	20	130	165	46	96	5.2	160	266	
KSZ-H-150	Z-100/150-MF-200-138	112 B14B	KUZ-38	-38 / 28	M12x40	M10x351)	138	200	20	130	165	46	96	5.2	160	266	
KSZ-H-150	Z-100/150-MF-B+P-200	132 B14C	KUZ-38	-38 / 38	M12x150	M10x651)	161	200	48	130	165	46	96	8.7	160	246	

1) incl. spring washers 2) incl. nuts 3) only valid for these combinations. CAUTION: Permissible torque for each KSZ-H must be observed.

Coupling KUZ-KK

Coupling with split shells

Material: high-tensile aluminium,
 Split shells permit easy radial insertion,
 High concentricity, High clamping forces,
 Low moment of inertia, Stepless adjustment facility
 thanks to the clamp hub rather than a fitted drive key,
 Drive keyway available on request
 Elastomer - Star "ZIMM green":
 Permanently free of play and dampens vibration,
 Temperature range: 0°C to +70°C
 reduced to -20°C up to +100°C

Standard bores "d" mm

KUZ-KK-16	8, 9, 10, 11, 12, 14, 15, 16
KUZ-KK-24	9, 10, 11, 12, 14, 15, 16, 18, 19, 20, 22
KUZ-KK-32	10, 11, 12, 14, 15, 16, 18, 19, 20, 22, 24, 25, 28, 30, 32
KUZ-KK-35	12, 15, 16, 18, 20, 22, 24, 25, 28, 30, 32, 35
KUZ-KK-45	16, 19, 20, 22, 24, 25, 28, 30, 32, 35, 38, 40, 42, 45
KUZ-KK-60	25, 28, 32, 38, 40, 42, 45, 48, 50, 55

Other diameter available on request

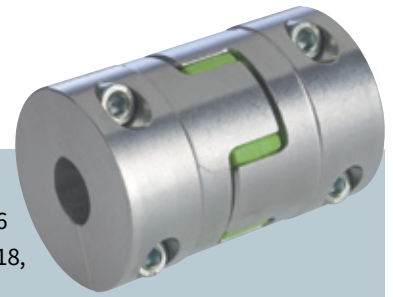

Dimensions

Coupling size	DA mm	DS mm	L mm	L1 mm	BK* mm	s mm	E mm	Set screw ¹ 10.9	Tightening torque Nm	Moment of inertia 10 ⁻³ kgm ²	Torsional stiffness C Nm/rad ^{1dyn}	Weight kg
KUZ-KK-16	32	32	54	21	15	1.5	12	M4	4	0.01	1375	0.1
KUZ-KK-24	42	44.5	66	25	17	1.5	16	M5	8	0.08	3700	0.2
KUZ-KK-32	56	57	98	40	30	2	18	M6	15	0.24	9917	0.55
KUZ-KK-35	67	68	114	47	35	2	20	M8	35	0.51	24417	0.9
KUZ-KK-45	82	85	134	55	40	2	24	M10	70	2.4	33667	1.6
KUZ-KK-60	102	105	156	65	50	2	26	M12	120	6	67667	2.7

*BK = Shaft extension clamping length ¹Bolt grade

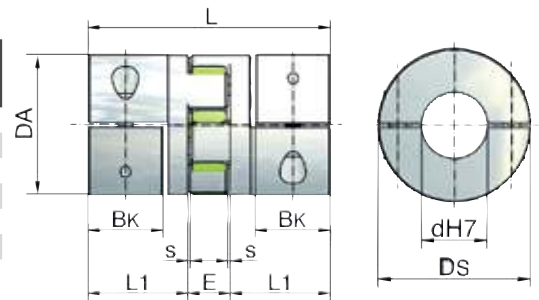

Torques

Coupling size	Elastomer Stars		max. transmittable torque of clamp hub depending on the bore diameter (damp force)																								
	Rated torque Nm	max. torque Nm	Ø8 Nm	Ø9 Nm	Ø10 Nm	Ø11 Nm	Ø12 Nm	Ø14 Nm	Ø15 Nm	Ø16 Nm	Ø18 Nm	Ø19 Nm	Ø20 Nm	Ø22 Nm	Ø24 Nm	Ø25 Nm	Ø28 Nm	Ø30 Nm	Ø32 Nm	Ø38 Nm	Ø40 Nm	Ø42 Nm	Ø45 Nm	Ø48 Nm	Ø50 Nm	Ø55 Nm	
KUZ-KK-16	16	32	19	21	23	26	28	33	32	37	-	-	-	-	-	-	-	-	-	-	-	-	-	-	-	-	-
KUZ-KK-24	21	42	-	-	45	41	45	52	56	60	67	70	74	81	-	-	-	-	-	-	-	-	-	-	-	-	-
KUZ-KK-32	75	150	-	-	65	60	65	76	82	87	98	104	109	120	131	136	153	164	175	-	-	-	-	-	-	-	-
KUZ-KK-35	200	400	-	-	108	-	108	-	135	120	162	-	188	206	216	235	-	315	301	-	-	-	-	-	-	-	-
KUZ-KK-45	405	810	-	-	-	-	-	-	-	325	-	386	406	447	488	508	568	610	650	772	-	854	915	-	-	-	-
KUZ-KK-60	660	1350	-	-	-	-	-	-	-	-	-	-	-	-	-	570	638	-	730	866	810	960	1029	1097	1141	1250	

Potential assembly errors (KUZ and KUZ-KK)

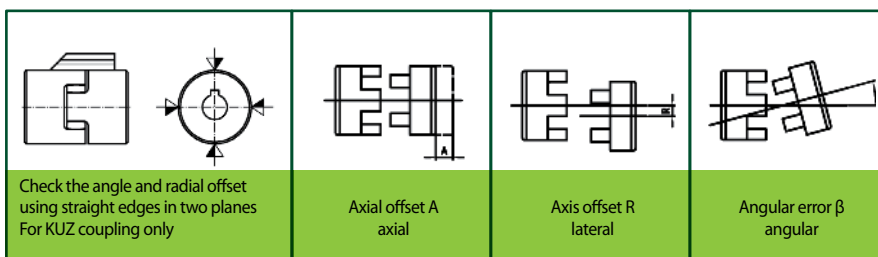

Permissible assembly error

Coupling size	max. axial offset in mm	max. axis offset in mm	Angular error in degrees
KUZ-KK-16	±1	0.08	1°
KUZ-KK-24	±2	0.08	1°
KUZ-KK-32	±2	0.1	1°
KUZ-KK-35	±2	0.15	1°
KUZ-KK-45	±2	0.12	1°
KUZ-KK-60	±2	0.14	1°
KUZ-09	0.8	0.15	1°
KUZ-14	0.75	0.4	0.5°
KUZ-19	0.75	0.4	0.5°
KUZ-24	1.2	0.2	0.9°
KUZ-28	1.4	0.22	0.9°
KUZ-38	1.5	0.25	0.9°
KUZ-45	1.8	0.25	1°
KUZ-55	2	0.32	1°
KUZ-60	2.1	0.36	1.1°
KUZ-70	2.2	0.38	1.1°
KUZ-75	2.6	0.42	1.2°
KUZ-90	3	0.48	1.2°

Ordering example:

KUZ-KK-32-20/24

Type of coupling _____
 Size _____
 Bore d end 1 _____
 Bore d end 2 _____

Connecting technology

Connecting Shafts VWZ

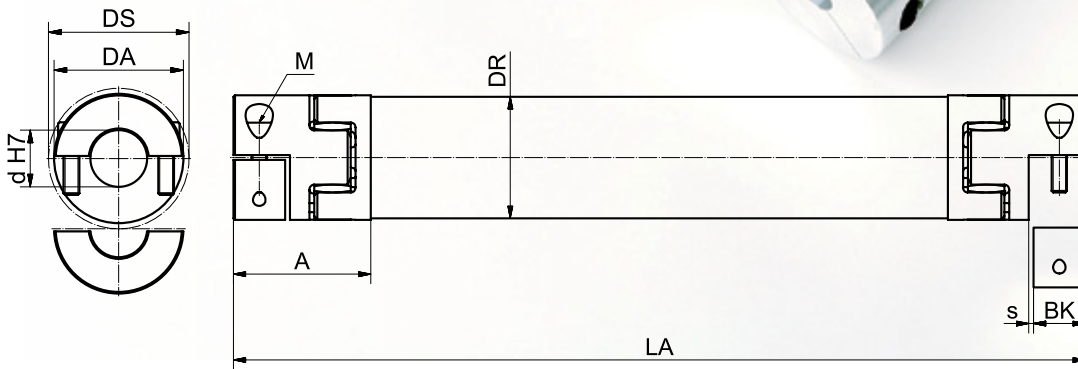

Standard bores "d" mm

VWZ-30	8, 9, 10, 11, 12, 14, 15, 16
VWZ-40	9, 10, 11, 12, 14, 15, 16, 18, 19, 20, 22
VWZ-60	10, 11, 12, 14, 15, 16, 18, 19, 20, 22, 24, 25, 28, 30, 32
VWZ-60V	12, 15, 16, 18, 20, 22, 24, 25, 28, 30, 32, 35
VWZ-80	16, 19, 20, 22, 24, 25, 28, 30, 32, 35, 38, 40, 42, 45
VWZ-100	25, 28, 32, 38, 40, 42, 45, 48, 50, 55

Other diameter available on request

Ordering example:

VWZ-60-LA1800-20/25

Size

Length

Bores for couplings

Advice

ZIMM VWZ shafts of 500 mm length and more are checked for concentricity as standard!

Dimensions, Technical data

Size	Dimensions							Clamping screw		Moment of inertia		Torsional stiffness		Weight	
	DA mm	DS mm	DR mm	BK* mm	s mm	A mm	LA min mm	M 10.9	Tightening torque Nm	Per coupling 10 ⁻³ kgm ²	Tube/m 10 ⁻³ kgm ²	Per star C _{Tdyn} Nm/rad	Per tube/m C _{Tdyn} Nm/rad	Both couplings kg	Tube/m kg
VWZ-30	32	32	30	15	1.5	34	99	M4	4	0.01	0.11	1375	1104	0.14	0.58
VWZ-40	42	44.5	40	17	1.5	46	133	M5	8	0.08	0.2	3700	2332	0.36	0.76
VWZ-60	56	57	60	30	2	63	177	M6	15	0.24	0.8	9917	8292	0.94	0.97
VWZ-60V	67	68	60	35	2	73	205	M8	35	0.46	0.8	24417	8292	1.42	0.97
VWZ-80	82	85	80	40	2	84	249	M10	70	2.4	3	33667	29102	2.98	2
VWZ-100	102	105	100	50	2	97	283	M12	120	6	5.8	67667	58178	4.62	2.47

*BK=Shaft extension clamping length

Torques

Size	Elastomer Star		max. transmittable torque of clamp hub depending on the bore diameter (clamp force)																							Coupling type			
	Rated torque Nm	max. torque Nm	Ø9 Nm	Ø10 Nm	Ø11 Nm	Ø12 Nm	Ø14 Nm	Ø15 Nm	Ø16 Nm	Ø18 Nm	Ø19 Nm	Ø20 Nm	Ø22 Nm	Ø24 Nm	Ø25 Nm	Ø28 Nm	Ø30 Nm	Ø32 Nm	Ø35 Nm	Ø38 Nm	Ø40 Nm	Ø42 Nm	Ø45 Nm	Ø48 Nm	Ø50 Nm		Ø55 Nm		
VWZ-30	16	32	21	23	26	28	33	32	37	-	-	-	-	-	-	-	-	-	-	-	-	-	-	-	-	-	-	-	KUZ-KK-16
VWZ-40	21	42	-	37	41	45	52	56	60	67	70	74	81	-	-	-	-	-	-	-	-	-	-	-	-	-	-	-	KUZ-KK-24
VWZ-60	75	150	-	55	60	65	76	82	87	98	104	109	120	131	136	153	164	175	-	-	-	-	-	-	-	-	-	-	KUZ-KK-32
VWZ-60V	200	400	-	-	-	108	-	135	120	162	-	188	206	-	235	-	-	301	315	-	-	-	-	-	-	-	-	KUZ-KK-35	
VWZ-80	405	810	-	-	-	-	-	-	325	-	386	406	447	488	508	568	610	650	711	772	-	854	915	-	-	-	-	KUZ-KK-45	
VWZ-100	660	1350	-	-	-	-	-	-	-	-	-	-	-	-	570	638	-	730	-	866	914	960	1029	1097	1141	1250	-	KUZ-KK-60	

The max. torque is limited either by the star or by the clamping force

Connecting shaft VWZ - Length calculation

Maximum length dependent on speed

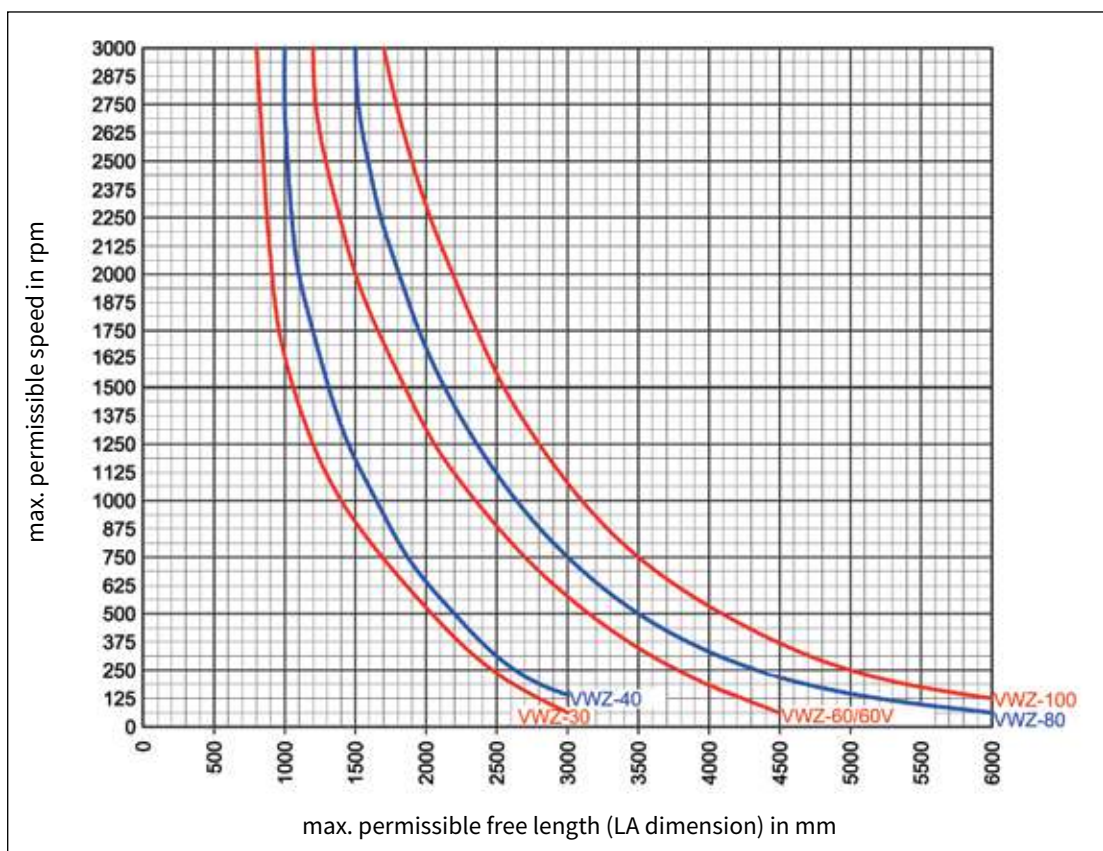

max. permissible offset

Lateral offset:



Kr max. 1.5 mm pro 100 mm LI

Angular offset:



max. 2° (1° per coupling)

Axial offset:



approx. +/- 1 to 2 mm

Installation

By using split shell couplings, connecting shafts can be mounted while Gearboxes or Screw Jacks have been installed first. Simply attach the connecting shafts to the drive shafts using the split shell couplings and fix them with the mounting screw using a torque wrench (no drive key needed).

Screw tightening torque according to the table on page 10.



Connecting Shaft

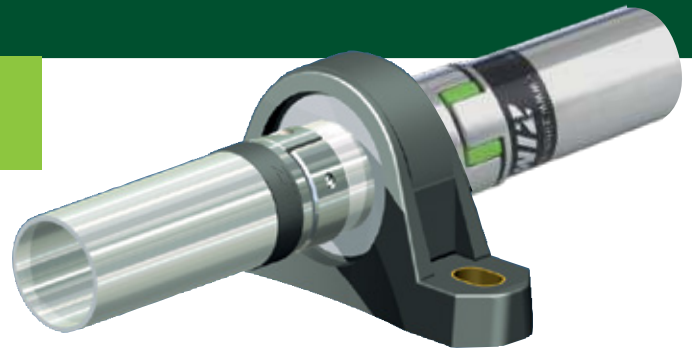

pedestal bearing STL

VWZ with rigid hub for pedestal bearing use

The installation situation is very important when selecting shaft dimensions. For example, the cost of a larger diameter connecting shaft not requiring additional pedestal bearing support can be considerably less than the cost of a smaller connecting shaft requiring costly sub-structures for the additional pedestal bearing. For this version we use the rigid hub so that no radial misalignment can occur in the pedestal bearing.

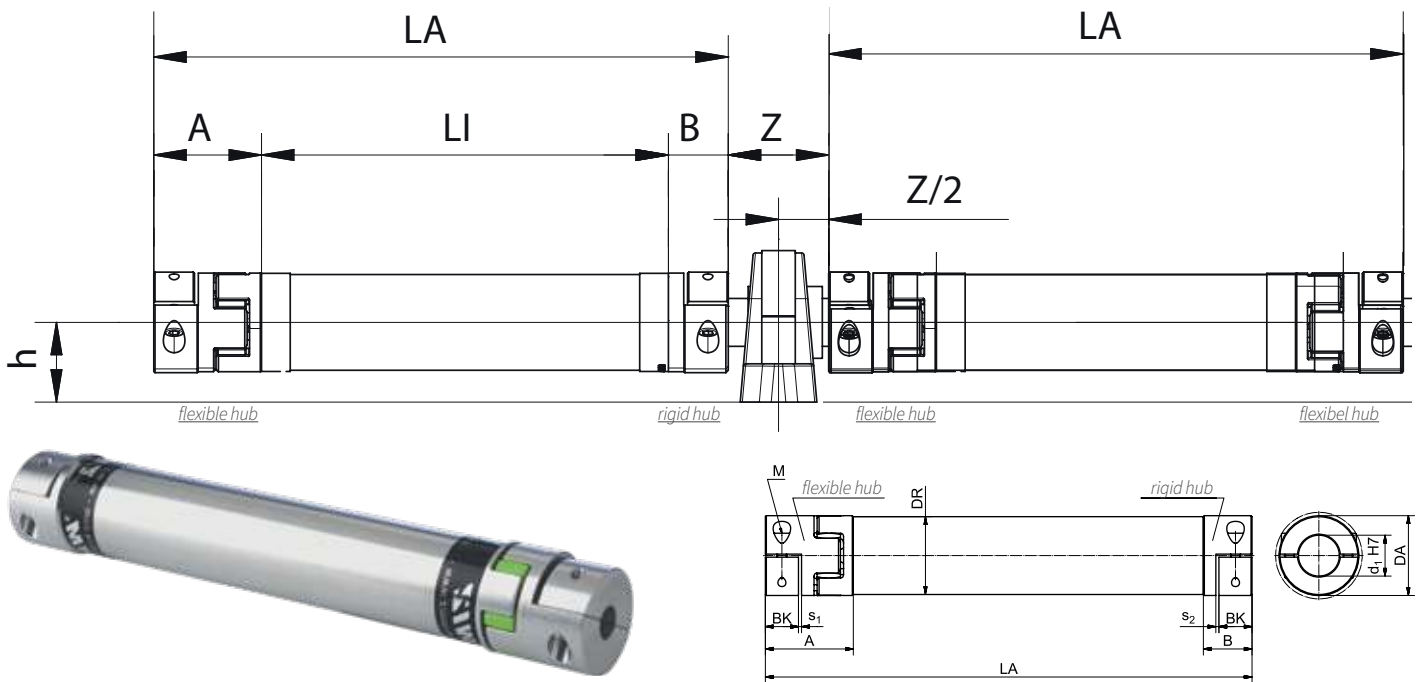

Dimensions with pedestal

Size	A	B	Z	L _{wz}	d1	h
VWZ-30	34	20	44	74	15	30.2
VWZ-40	46	25	42	76	20	33.3
VWZ-60	63	40	42	102	20	33.3
VWZ-30	34	20	44	74	15	30.2
VWZ-40	46	25	42	76	20	33.2
VWZ-60	63	40	42	102	20	33.2
VWZ-40	46	25	42	76	20	33.2
VWZ-60	63	40	42	102	20	33.2
VWZ-80	84	55	50	130	30	42.9
VWZ-40	46	25	42	76	20	33.2
VWZ-60	63	40	42	102	20	33.2
VWZ-60V*	73	42	60	130	30	42.9
VWZ-80*	84	55	50	130	30	42.9
VWZ-60	63	40	42	102	20	33.3
VWZ-60V	73	42	60	130	30	42.9
VWZ-80*	84	55	50	130	30	42.9
VWZ-60	63	40	42	102	20	33.2
VWZ-60V	73	42	60	130	30	42.9
VWZ-80	84	55	50	130	30	42.9
VWZ-60	63	40	42	102	20	33.2
VWZ-60V	73	42	60	130	30	42.9
VWZ-80	84	55	50	130	30	42.9
VWZ-80	84	55	50	130	30	42.9
VWZ-80	84	55	50	130	30	42.9
VWZ-100	97	65	70	170	50	57.2
VWZ-80	84	55	50	130	30	42.9
VWZ-100	97	65	70	170	50	57.2
VWZ-80	84	55	50	130	30	42.9
VWZ-100	97	65	70	170	50	57.2

Dimensions

Size	A	B	s1	s2	Bk*	d1	LA min
VWZ-30	34	20	2	1.2	15	15	85
VWZ-40	46	25	2	1.6	17	20	112
VWZ-60	63	40	2	2	30	20	154
VWZ-60V	73	42	2	2	35	30	175
VWZ-80	84	55	2	2	40	30	220
VWZ-100	97	65	2	2	50	50	251

*BK=Shaft extension clamping length

Ordering example:

VWZ-60-LA1800-25/20S
 Size _____
 Length _____
 Bore 1st side _____
 Bore 2nd side (S = rigid hub) _____

*Cannot be fitted with pivot mounts LB

Pedestal bearing STL

for connecting shaft VWZ

Housing material:

Grey cast iron, primed in blue

Bearing material:

Roller bearing steel

Temperature range:

-30°C to +120°C

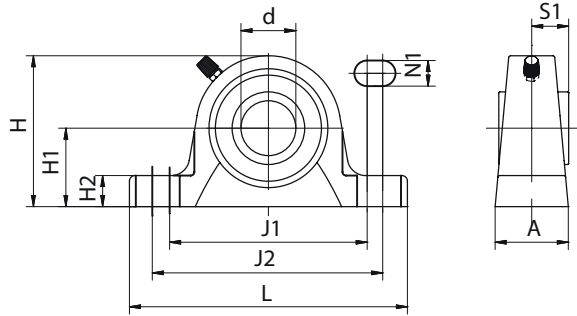

Dimensions

Part no.	d	A	H	H1	H2	J1	J2	L	N1	S1	kg
STL-15-G	15	32	56	30.2	14	88	106	127	11.5	15.3	0.47
STL-20-G	20	32	65	33.3	14	88	106	127	11.5	18.3	0.59
STL-30-G	30	40	82.5	42.9	17	108	127	152	14	22.2	1.1
STL-40-G	40	48	99	49.2	19	125	146	175	14	30.2	1.85
STL-50-G	50	54	114.5	57.2	22	149	165	203	18	32.6	2.7

Shaft extension WZ

for connecting shaft VWZ

Material: Steel, ground

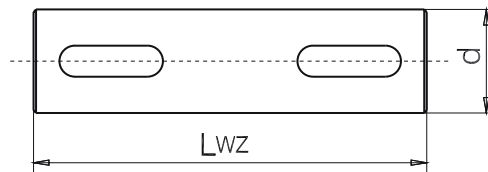

Dimensions

Part no.	d1	LWZ	kg
WZ-15/74-?P	15	74	0.1
WZ-20/76-?P	20	76	0.19
WZ-20/102-?P	20	102	0.25
WZ-30/130-?P	30	130	0.72
WZ-40/170-?P	40	170	1.67
WZ-50/170-?P	50	170	2.61

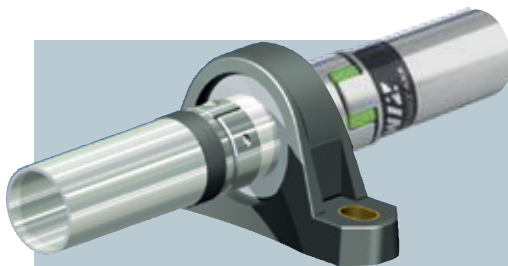

Examples:

VWZ with rigid hub,
for pedestal bearings.

Shaft extensions without fitted key (OP)

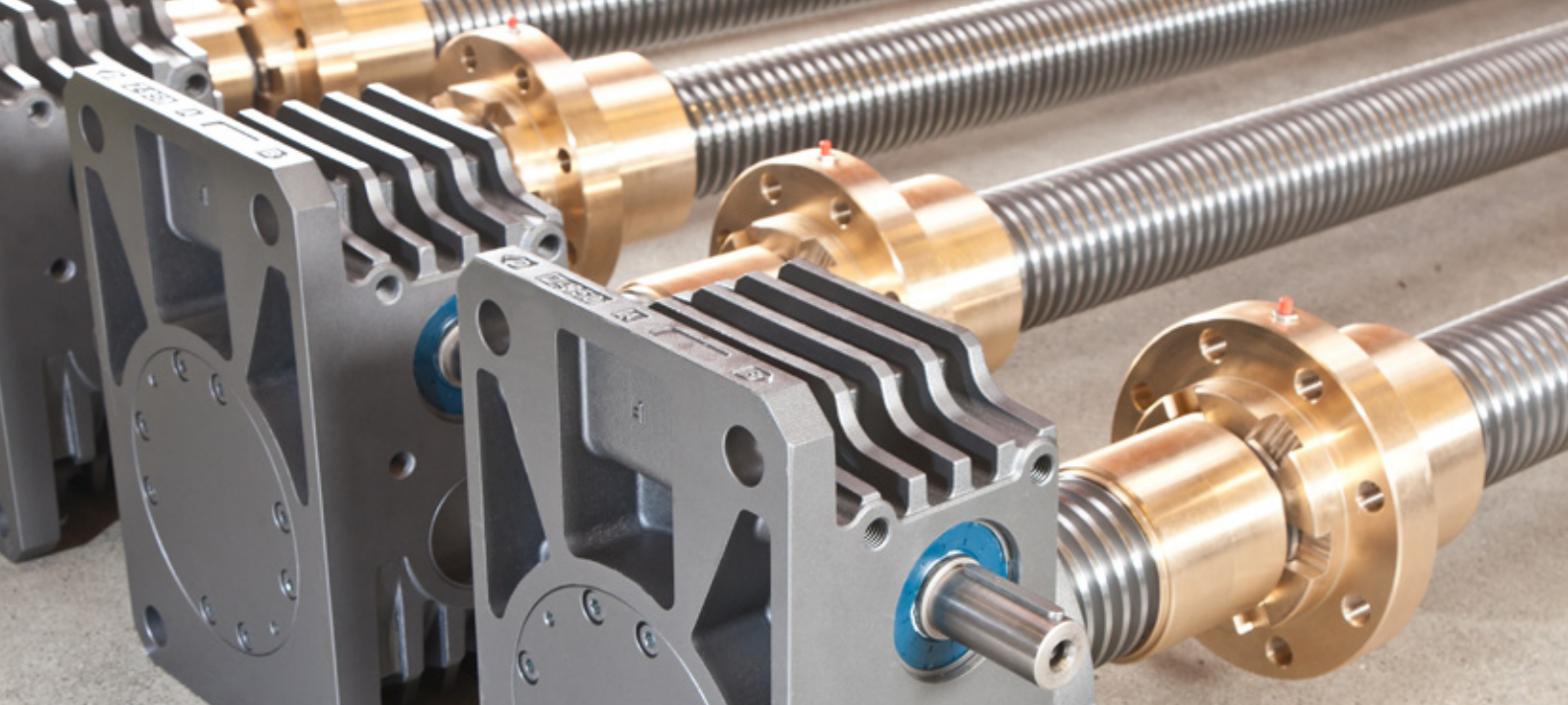

Discover more about

ZIMM has established itself as a leading manufacturer of quality screw jack systems and exports to renowned mechanical engineering companies worldwide.

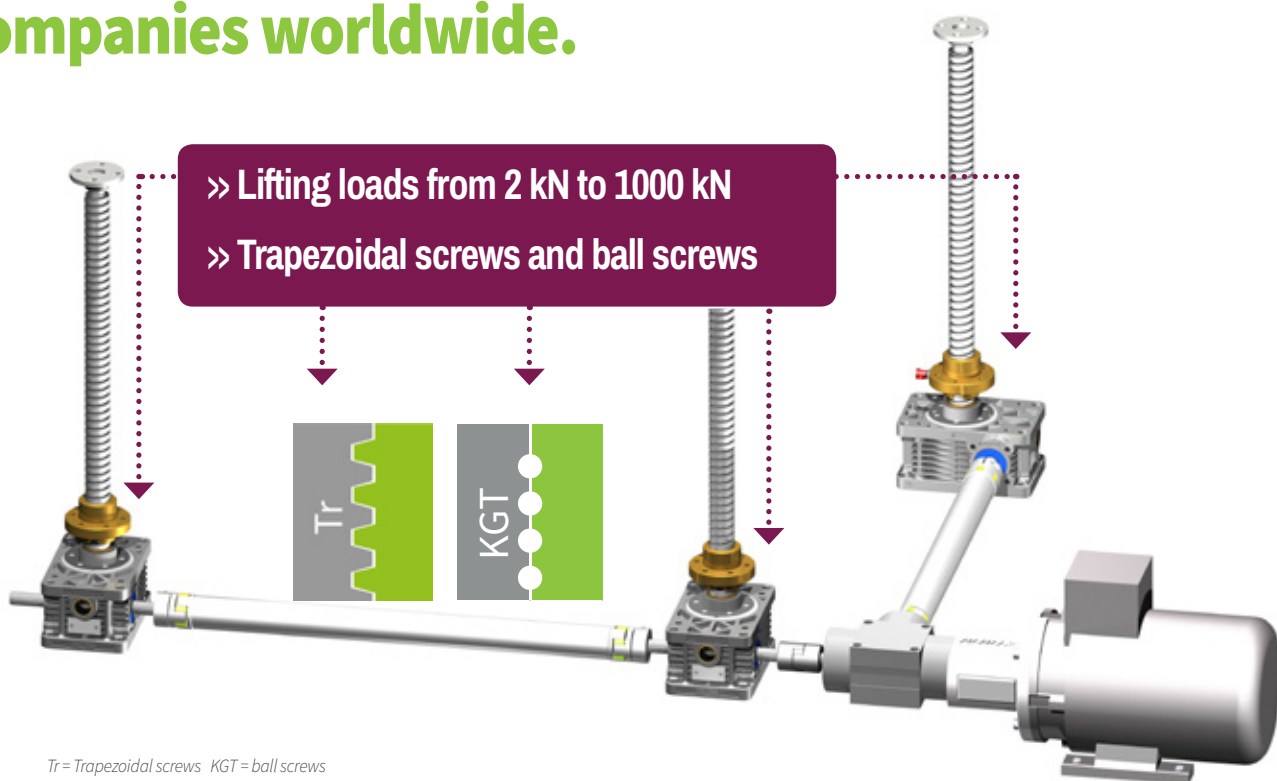

Tr = Trapezoidal screws KGT = ball screws

Unique

Online Product configurator

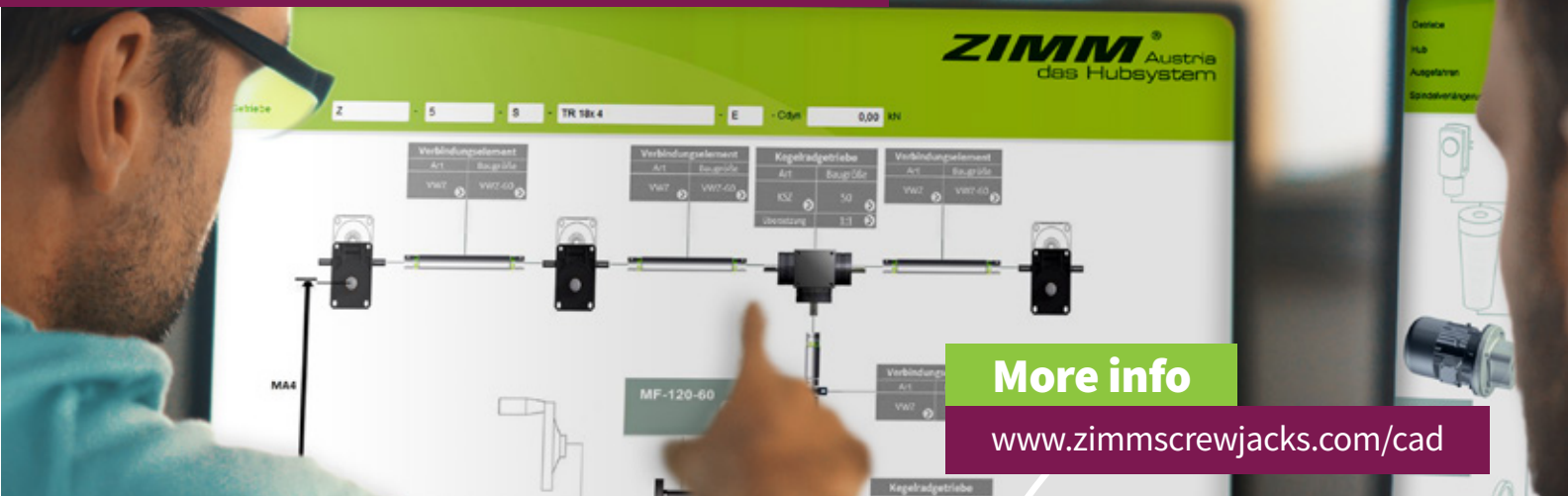

ZIMM®



Video

Convenient and efficient

Now with the ZIMM online product configurator, it is possible to design a complete screw jack system solution.

The solution consisting of multiple screw jacks, connection elements and suitable bevel gearboxes.



Don't waste your time!
Use the unique online
configurator for
screw jack systems.

– The ZIMM Team

ZIMM®



ZIMM Maschinenelemente GmbH + Co KG

Millennium Park 3

6890 Lustenau/Austria

Phone: 00 43 55 77 / 806-0

email: info@zimm.at

Website: www.zimm.com